



TEX MIRROR

FITTING INSTRUCTIONS

The Tex Universal Door Mirror can be fitted to a wide range of cars and light vans without having to remove door panels, by following the instructions outlined below.

1. With the aid of a second person, locate a clear unobstructed position for the door mirror when viewed from the driving seat. Ensure that the fixing screws will not foul the window and that the mirror is not at the limit of adjustment in any one plane.
2. Mark the selected position with a 75mm long strip of masking tape to prevent the drill bit running and scratching the door panel below.
3. Two types of support (plinth) are supplied. Choose whichever is the most suitable for the door shape.
4. Place plinth as applicable in position as a template. Mark the hole positions. Carefully drill two holes using a $1\frac{7}{64}$ or 7mm drill bit.
5. Remove the masking tape and push both bosses of the plinth through the drilled holes. Insert the screws and tighten down until plinth is firmly fixed to the door.

CAUTION: Do not over-tighten as this will strip the plastic bosses and will result in a loose mounting.

6. Slacken the grub screw on the mirror-stem and fit over the plinth.

Tighten the grub screw until the mirror is firm.
NB To adjust mirror-head, slacken the adjusting screws by no more than $1\frac{1}{2}$ turns and re-tighten after adjustment.

* Plinth (c) is not recommended for use on MG Midget or BL Mini. The correct Chrome Plinth M99987 (GAM7000) should be used.

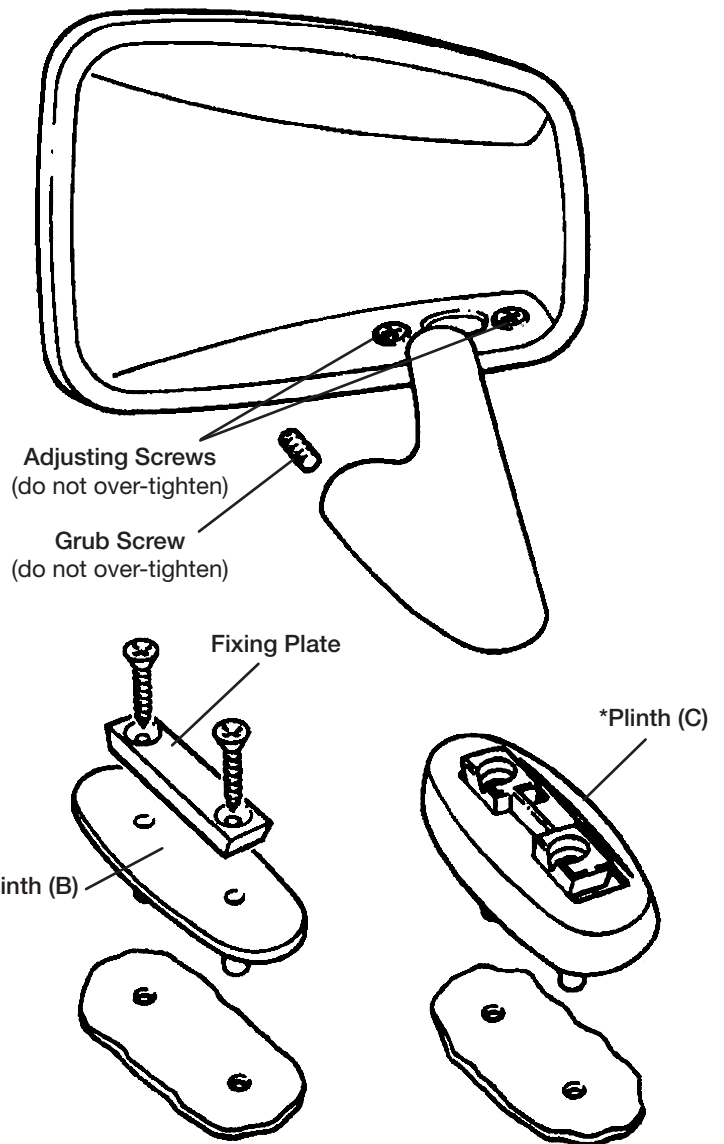

www.texautomotive.com

Tex Automotive Limited

Range Road, Cotswold Business Park, Witney, OX29 0YB United Kingdom

T: +44 (0)1993 893500 | E: info@texautomotive.com